

SPECIFICATION

9.0 SPECIFICATION

Capacity	Eight radix of capacity:1.0,1.2,1.5,2.0,3.0,5.0,6.0,7.5,8.0 Capacity 1kg-800t	
Resolution	0.00001~5000	
Response	2~3 seconds	
Display	LCD display with backlight/LED display	
Tare	Equal to Max capacity	
Over-load alarm	auto alarm when load over capacity+9d	
Over-load capacity	Protect automatically when the load is 125% of capacity	
Source	Rechargeable battery	DC 6V 4Ah
	Adaptor	AC 220V/DC 10V 500mA
Power	LCD:Backlight 50mA; No backlight 30mA; LED: 150mA	
Temperature	Storage -10~+50 C	Work 0~+40 C
Humidity	Storage 5%~90% R.H. Work 10%~80% R.H.	
Net/gross weigh	IND-L: 1.35/1.53kg	IND-J: 2.17/2.38kg

Load Cell connection instruction:

- 1、 +5V 2、 AGND
- 3、 +IN 4、 -IN

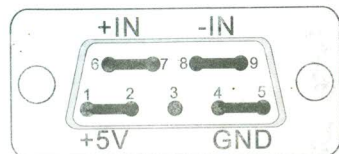
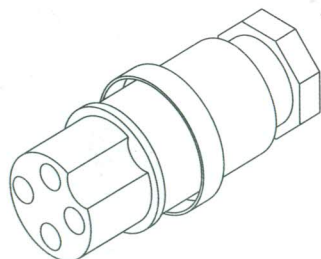
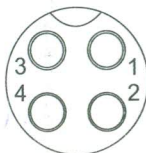

Weighing Balance

Operator

Manual

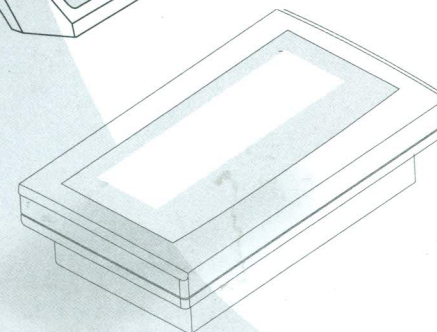
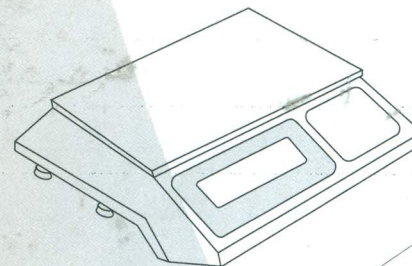

STAR TO USE

1.0 STAR TO USE AND INSTALL -----	1
2.0 INSTALL、KEY、DISPLAY AND FUNCTION -----	2
3.0 FUNCTION -----	3
4.0 MENU -----	4-5
5.0 UNIT CONVERSION -----	5
6.0 SPECIFICATION -----	6

1. caution

- 1.1 do not spill liquids on the balance.
- 1.2 avoid installing the balance in direct sunlight.
- 1.3 avoid overloading or dropping material onto the platform.
- 1.4 if the balance is not to be used for a long period of time, remove all batteries from the battery compartment. please recharge every three months and charge before use.
- 1.5 please use the standard adapter and individual socket.
- 1.6 please charge when Lo-Bat sign is blinking.
- 1.7 please warm-up the balance for 15-20 minutes.
- 1.8 please place your balance on a firm and level table.
- 1.9 calibration may be required before weighing or when the balance is initially installed or moved from a location.

2. Star to use

- 1.0 Distribution (indicator)
 - (1) Adapter (2) holder (3) Plastic Cover (4) User Manual (5)

Loadcell Plug

- 2.0 How to turn on
Press the power switch which is in the right side of the indicator to "ON". As picture(1).

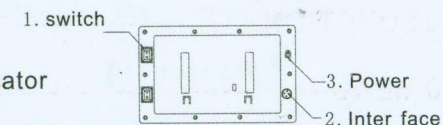

3.0 How to begin

- (1) Put the loadcell plug is to the hole, As picture (2).
- (2) Turn on the power .
- (3) Please wait 2-3 minutes for warm-up .
- (4) If the display show before use is not "0" before use, please press <zero> key to get "0" .

4.0 Wrong information

- (1) "ADO---": Inner code is too big.
- (2) "ADL---": Inner code is too small.
- (3) "OVR---": Weight is out of max exceed.

Guides to installment of the indicator

1. Firstly putting the cable (6) through the pillar (7), and then insert the pillar (7) into base, fastening the fixed screw.
2. After putting the cable (6) through the holder (3).
3. Then, insert the holder (3) into the bracket (8) of indicator. Joining the load cell connector (2) with interface (9). And linking the cable (4).
4. Adjusting the holder (3) for right position, and then fasten the fixed screw on the display.

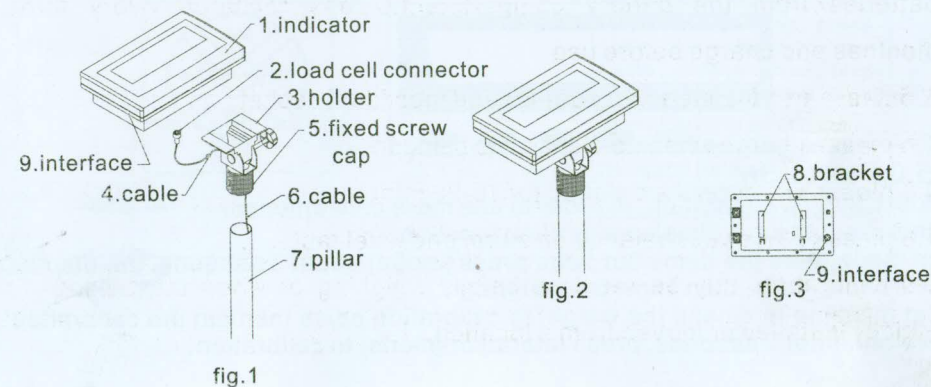

Installment Guides to IND-J

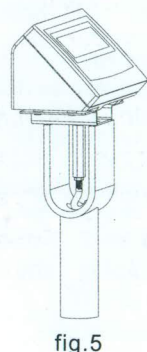
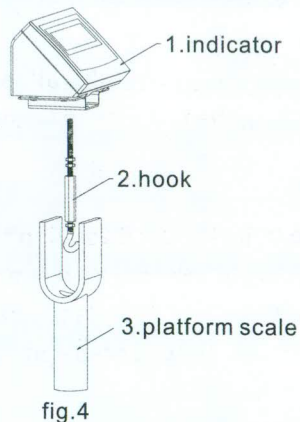

3.0 Instruction of the key

- 3.0.1 Zero tracking: When there is no weigh in, it appear figure, should press this key to return to zero.
- 3.0.2 Tare: Put the case, press "tare" and put the item down,you could know the weigh.
- 3.0.3 Unit: Choose unit.
- 3.0.4 Alarm: When weigh in, press "Alarm", it will enter into setting.
- 3.0.5 Mode: When weigh in, press "mode" enter into inner setting, the details as attachment.(1)

4.0 Display

4.0.1 LED direction form left to right: Low-bat 、 tare 、 zero 、 stable 、 pcs and units. Please wait for the "stable" light turn to red to get the accurate weighing value.

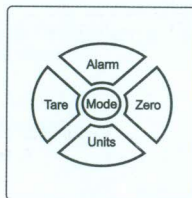
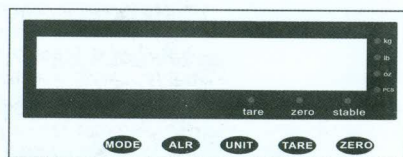

5.0 Function

5.0.1 Simple calibration, in order to use more convenience, this product have simple calibration function. in mode, take the items out , and press [mode] about 3 seconds, the display will show -CAL-, then show the weight ,at this time to amend the weight to calibration poise then put the calibration weight, after 3 seconds, press [alarm] or [mode] to calibration.

Attentions: When calibration, if the result of value if calibration weight and internal calibration are differ 100%, the calibration is not pass. Such as: if put 10kg weight poise on, the internal calibration is 10kg, the calibration is pass, is simple calibration is over 20kg or less then 5kg, the calibration is not pass.

5.0.2 Simple counting function(option)

When weighing, press (units) to change the units to pcs, if you don't reset before, the display will be "0", at the same time put the item on it , and press [mode], the display will be "N-XXX", XXX means quantity of items, press [units] to amend location of twinkling, when you finished, please press [mode] to weight , at the same time you also could take the figure.

6.0 Weigh check setting

Display	Function	Adjust
-H-L-	Upper limit and lower limit alarm, H means upper limit range, L means lower limit range, which is twinkling means the load on the pan is over the upper limit or lower limit, the alarm beeps, such as: if left is twinkling, it means the load is over the upper limit, the alarm beeps, if not, it means the function is to be closed.	Press [units] to amend, press [alarm] to next parameter
HXXXXX	This is upper limit range	Press [units] to amend the lacion of twinkling, press [tare] and [retare]to amend figure, when finished, press [alarm] enter to next
LXXXXX	This is lower limit range	Press [units] to amend the lacion of twinkling, press [tare] and [retare] to amend figures, when finished, press [alarm] to reture to beginning of weight.

MENU

7.0 User Setting

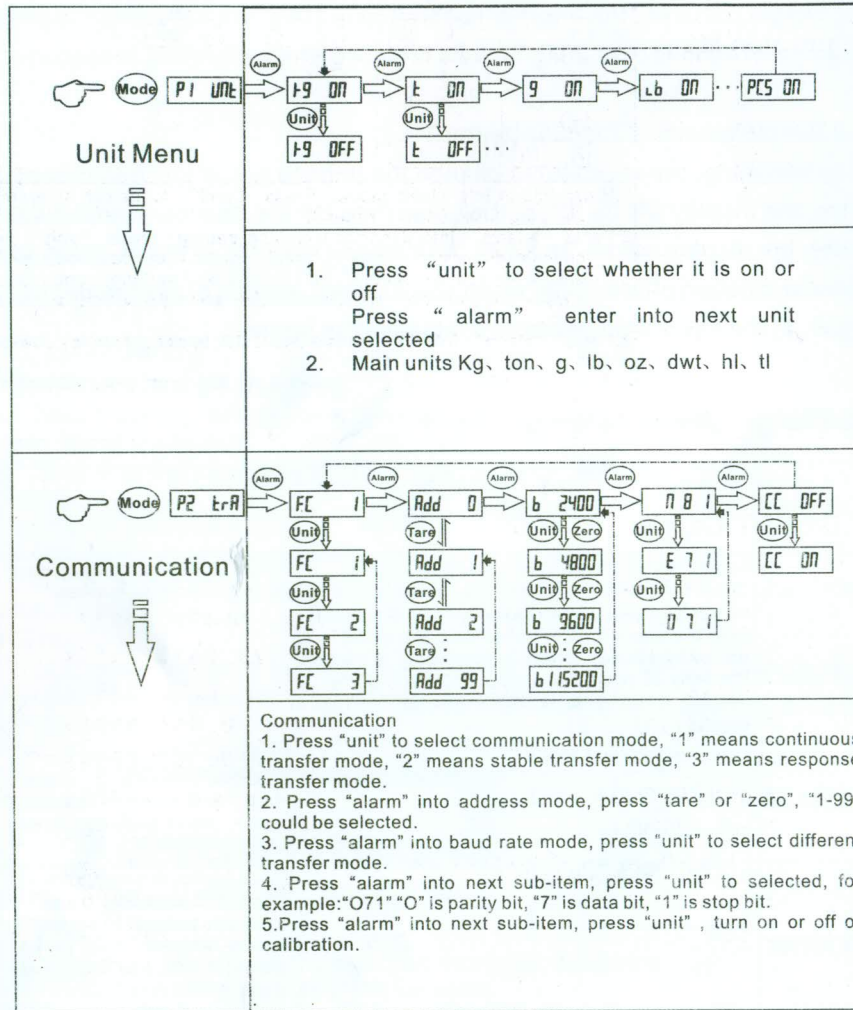

MENU AND UNIT

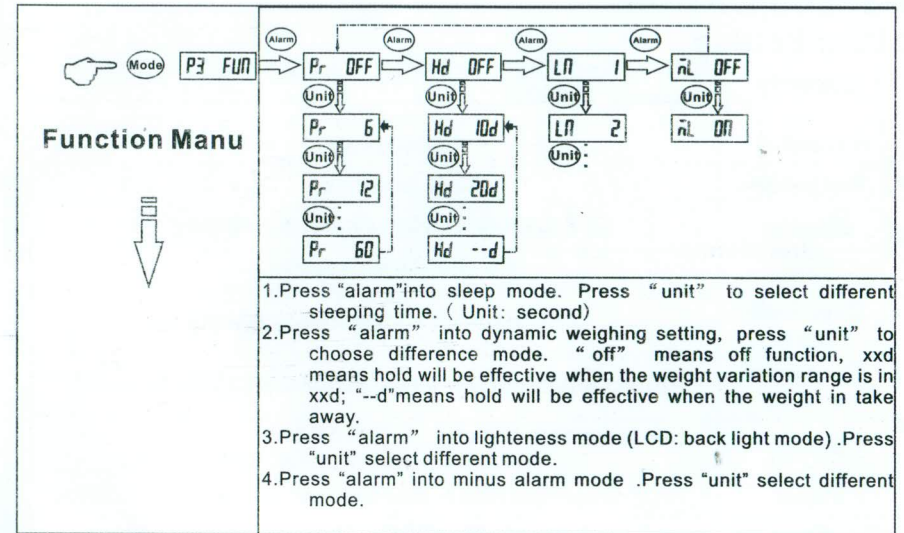

8.0 UNIT CONVERSION

1 ct (MET. CARAT)	=	0.2 g
1 lb (AVOIRDUPOIS POUND)	=	453.59237 g
1 oz (AVOIRDUPOIS OUNCE)	=	28.349523125 g
1 dr (AVOIRDUPOIS DRAM)	=	1.7718451 g
1 gn (GRAIN) (U. K)	=	0.06479891 g
1 ozt (TROY OUNCE)	=	31.1034768 g
1 dwt (PENNYWEIGHT)	=	1.55517384 g
1 mm (MOMME)	=	3.749996 g
1 t l. J (HONG KONG JEWELRY Tael)	=	37.4290018 g
1 t l. T (Tael) (TWN)	=	37.49995 g
1 t l. H (HONG KONG TQEL)	=	37.799375 g
1 t (TOLA) (INDIA)	=	11.6638038 g