

# **JIK-6 series**

---

## **User's Manual**

---

# CONTENTS

【PRECAUTIONS】 .....	1
【Installation】 .....	1
【FUNCTIONS】 .....	3
【 ZERO 】 .....	6
【 TARE 】 .....	7
【 PRE-TARE 】 .....	9
【 SELECTION OF WEIGHING UNIT 】 .....	11
【 INITIAL WEIGHING UNIT SETTING】 .....	12
【 ACCUMULATIONS 】 .....	14
【 ACCUMULATION MODE SETTING 】 .....	16
【 SIMPLE COUNTING 】 .....	17
【 PERCENTAGE % 】 .....	20
【 HI / LO Checking for weight 】 .....	21
【SERIAL NUMBER】 .....	23
【 STARTING SERIAL NUMBER SETTING 】 .....	24
【 TIME SETTING 】 .....	25
【 PRINT 】 .....	26
【 PRINT FORMAT SETTING 】 .....	27
【 SPACE BETWEEN LINES WHEN PRINTING 】 .....	28
【 PRINTING MODE SETTING 】 .....	29
【 SAMPLES OF BP-443D/ EZ-2P/ZEBRA/GODEX PRINTING FORMAT】 .....	30
【 SAMPLES OF SH-24 PRINTING FORMATS 】 .....	31
【Samples of SH-16 Printing Formats 】 .....	32
【 PARAMETER SETTING 】 .....	33
【 EXPLANATION OF PARAMETERS】 .....	34
【 CAPACITY / RESOLUTION SETTING 】 .....	36
【 DIVISION CONFIGURATION CHART 】 .....	37
【 TESTING MODE 】 .....	38
【ERROR MESSAGES】 .....	39
【 LCD CHARACTERS 】 .....	41
【CONNECTER】 .....	41
【DATA PROTOCOL】 .....	42
【RELAY MODULE DIAGRAM】 .....	43
【PRODUCT SPECIFICATIONS】 .....	44
【ASSEMBLY MANUAL OF JIK INDICATOR AND SUPPORT STAND】 .....	45
【 FIXING SCREW INSTRUCTION FOR JIK 】 .....	46
【 SINGLE POINT CALIBRATION FOR WEIGHT】 .....	47

## **【PRECAUTIONS】**

The scale or indicator should always be used in an environment which is free from excessive air currents, corrosives, vibrations, temperatures and humidity extremes. These factors will affect displayed weight readings.

### **DO NOT use the scale or indicator**

- Next to open windows or doors causing drafts or rapid temperatures changes!
- A temperature between -10 ~ 40 degree Celsius is recommended.
- Near air conditioning or heat ventilations!
- Near vibrating, rotating or reciprocating equipment!
- Near magnetic fields or equipment that generates magnetic fields.
- On a rough work surface!

### **Leveling the scale**

(when the indicator is connected to a platform)

Always adjust the scale to a level position with level adjusters until the bubbles appear in the center circle of the level indicator!

### **Battery**

Recharged the battery whenever the symbol  is flashing; this indicates that battery level is low. Charge the battery with the DC 9V / 1A adaptor attached. And when the battery is charging, the LED is red and when is fully charged the LED turns green. (it takes approximately 6 hours to charge battery completely)

## **【Installation】**

### **Load Cell connections**

- 7 pin Load Cell connections

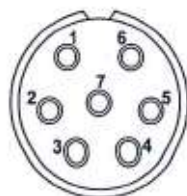

PIN	Load Cell Connections
PIN1	EXCITATION+
PIN2	SENSE+
PIN3	EXCITATION-
PIN4	SENSE-
PIN5	SIGNAL+
PIN6	SIGNAL-
PIN7	GND

#### 6-Wire Load cell Application

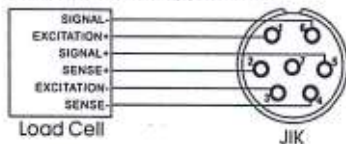

#### 4-Wire Load cell Application

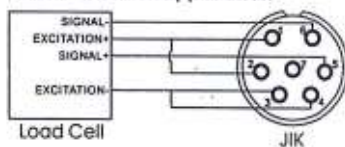

### ■ Setting up the platform

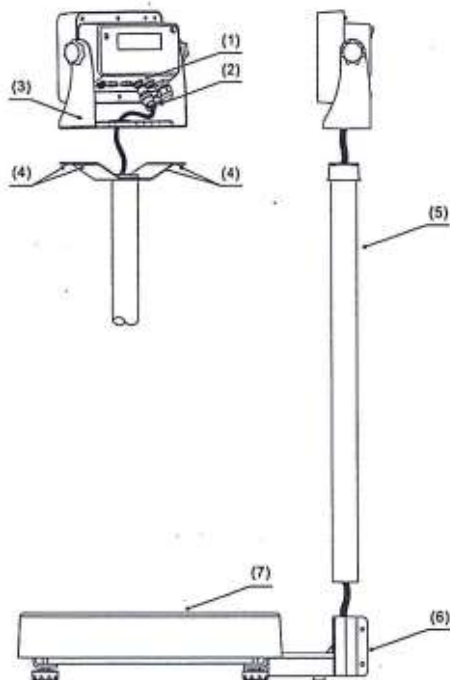

1	Load Cell (male) connector (7 pin)
2	Load Cell (female) connector (7 pin)
3	Indicator Stand
4	Supporter between frame and indicator
5	Pole
6	Pole holder
7	Platform

Assemble the scale by the following steps (refer to the diagram above)

1. Pull the load cell cable through pole holder (6) up. Install pole (6) into the pole holder (5), and fix the pole with cross-headed screws.
2. Pull load cell cable through indicator supporter (4) to connect to the indicator.
3. Install Indicator supporter (4) and indicator stand (3) together.
4. Adjust the indicator to adequate viewing angle and tighten the screws located on each side of the Indicator.

## 【FUNCTIONS】

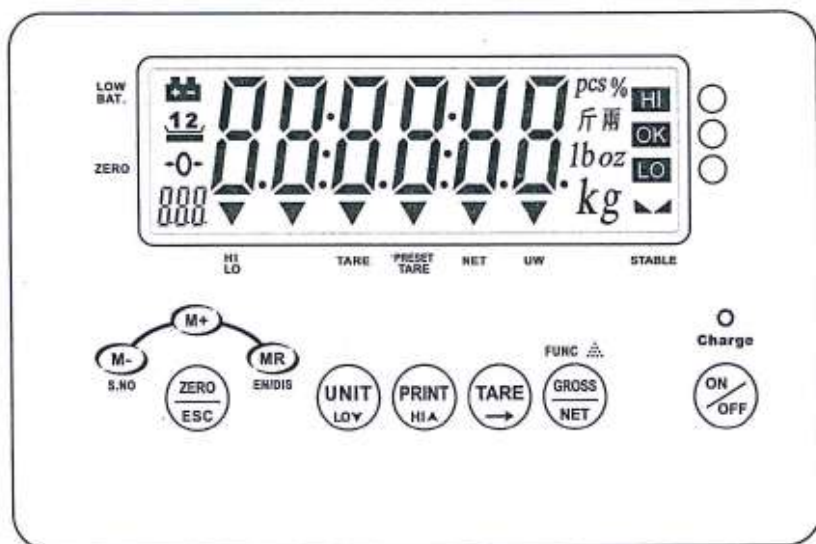

### LCD display and function of each key











### ■ LCD display and explanation



LCD display	Explanation
<i>kg</i>	Weighing unit in Kilograms or Grams
-0-	" ZERO " sign
▾	Stable sign when the weight reading is stable
<i>pcs</i>	Piece counting function
%	Percentage function
▼	Indication sign for insufficient unit weight, net weight, tare, pre-tare, Hi-Lo limits, auto tare.
000 000	Operation message display
HI OK LO	HI, OK and LO limits indication
<i>lb oz</i>	Additional weighing units
	Battery Power is weak

### ■ Explanation of each key

Position	Keys	Main function	Secondary functions
		Turns the indicator on or off	
1		To delete the accumulation weights or certain number of accumulated weight	<ol style="list-style-type: none"> <li>1. change the digit when in parameter mode ( decreased)</li> <li>2. change the number when in HI-LO checking mode</li> <li>3. setting of serial number</li> <li>4. setting of date &amp; time</li> </ol>



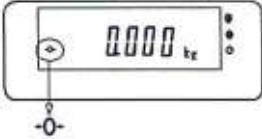
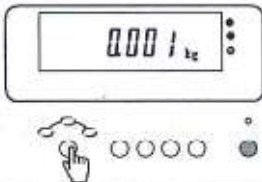

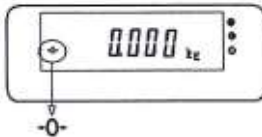



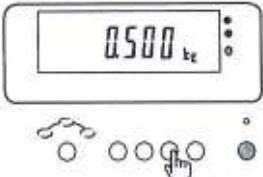

2		Accumulation	<ol style="list-style-type: none"> <li>1. Change the digit when in parameter model (increased)</li> <li>2. Change the number when in HI-LO checking mode</li> <li>3. Press this key to enter the testing mode</li> <li>4. Change the setting of accumulation mode</li> </ol>
3		Set the display to zero	<ol style="list-style-type: none"> <li>1. Press to escape from parameter setting without saving</li> <li>2. Cancel function</li> </ol>
4		Recall total accumulation weights or certain number of accumulated weights	<ol style="list-style-type: none"> <li>1. Enable or disable the HI-LO checking function</li> <li>2. Capacity / division setting</li> </ol>
5		Switch the weighing unit from one to another	<ol style="list-style-type: none"> <li>1. To enter to weighing units setting mode</li> <li>2. To enter into HI-LO checking mode and key in the LO limits</li> <li>3. Setting the space when in printing format mode</li> </ol>
6		Send the data stored in memory to PC or printer when pressed	<ol style="list-style-type: none"> <li>1. To enter to printer mode</li> <li>2. To enter into HI-LO checking mode and for key in HI limits</li> </ol>
7		Tare	<ol style="list-style-type: none"> <li>1. To enter to pre-tare mode</li> <li>2. Move the cursor to left when in parameter setting mode</li> </ol>
8	 	Switch the weight between GROSS/NET	<ol style="list-style-type: none"> <li>1. To enter to internal parameter setting</li> <li>2. Sample storing mode when in piece counting mode</li> <li>3. Reset the serial number when in serial number mode</li> <li>4. To enter to print format setting mode</li> </ol>

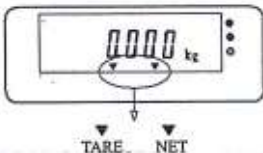
## 【 ZERO 】

	<p>(1). The indicators zero point <b>-0-</b> sign is shown in the left diagram. When the display is at zero, this sign will appear.</p>
	<p>(2). Press  to return to zero when the display is without the <b>-0-</b> sign.</p>
	<p>(3). Now, the <b>-0-</b> sign appear and the scale is in zero point.</p> <p>Remarks: The range of zero point is +/- 2% of the max capacity. Example : the zero range of 60kg is +/- 1.2kg</p>

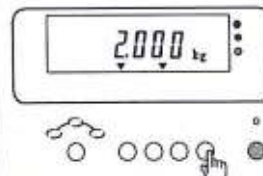

## 【 TARE 】



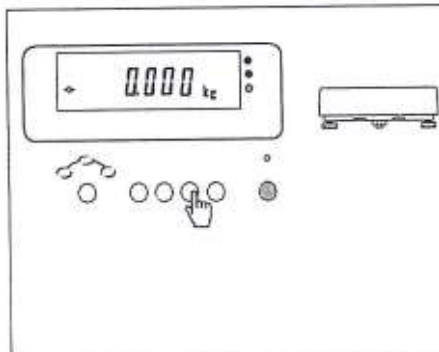



	<p>(1). Place a container, for example 0.500 kg on the weighing pan.</p> <p>(2). Press  key.</p>
	<p>(3). After pressing TARE, indication sign for TARE and NET will appear. The scale is now in net weight condition.</p>
	<p>(4). Place a weight object of 2.00kg into the container. The net weight is reading as 2.000 kg.</p>
	<p>(5). Press  key.</p> <p>(6). Display will show the gross weight as 2.500kg (inclusive of the TARE weight). Net weight sign is disappear.</p>
	<p>(7). Press  again and display will show the NET weight again as 2.000 kg with the sign NET again.</p>
	<p>(8). Remove all objects from the weighing pan and wait for the zero  sign to appear.</p>







- (9). Press  key .
- (10). The NET and TARE signs will disappear and the scale now return to Zero point.

Remarks: Weighing Range = Maximum Range – Tare Range

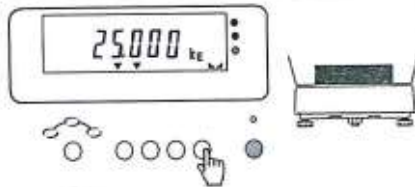

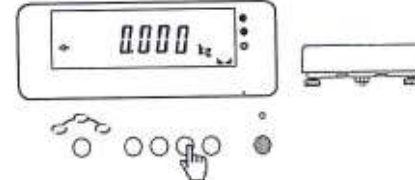



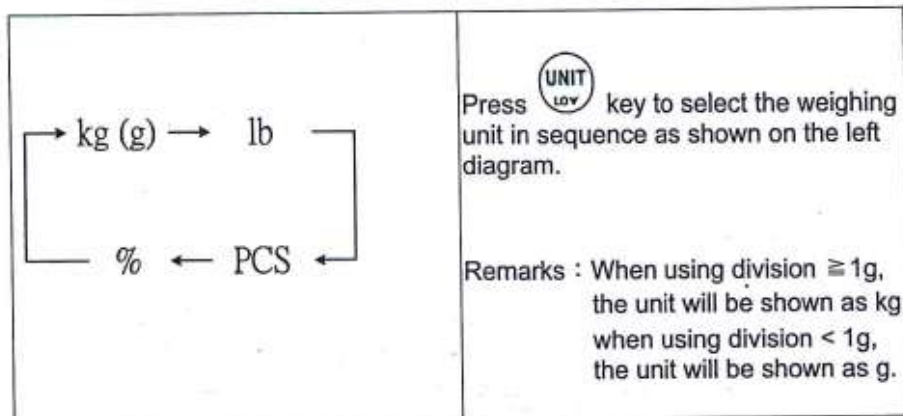

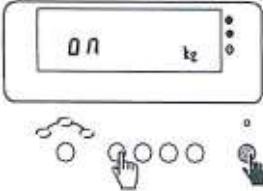

## 【 PRE-TARE 】

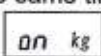
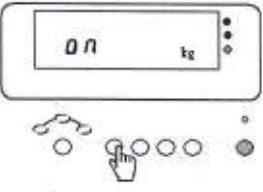
	<p>(1). Under normal weighing mode, press  key for 3 seconds, the display will show the pre-tare mode with last digit flashing. At the operation message display, you can see "kr"</p>
	<p>(2). Press  key to start the setting of the Pre-Tare value . "00000kg"</p>
	<p>(3). Press  key to move the cursor to the desired digit which needs to be changed . Example : <u>0</u>000kg.</p>
	<p>(4). Press  key to change the digit in increasing manner and  key to change the digit in decreasing manner. For example : <u>5</u>000kg, number 5 will be blinking .</p>
	<p>(5). Press  key to save the pre-tare changes and return to weighing mode .Now the display will show -5.000kg and zero point \, tare, pre-tare, net weight signs will appear in display!</p>

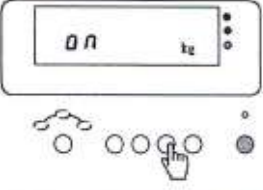
	<p>(6). Place the container (5.000kg) and weight mass(20.000kg) to the weighing pan. The display will show 20.000kg, the zero sign will disappear and this 20.000kg will be the Net weight .</p>
	<p>(7). Press  key and now the display will show 25.000kg, arrow pointing to NET disappear. This 25.000kg will be the gross weight of the weight object with the container.</p>
	<p>(8). Remove the container and weight object, display will show -5.000kg again.</p>
	<p>(9). Press  key and all the arrows pointing to NET, TARE, Pre-Tare will disappear. The scale returns to normal weighing mode with the zero sign on.</p> <p>Remarks: Weighing Range = Maximum Range – Tare Range</p>

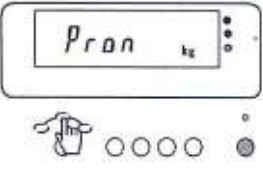

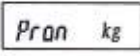
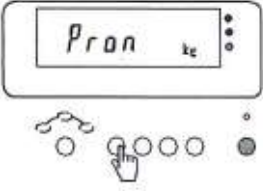
**【 SELECTION OF WEIGHING UNIT 】**

## 【 INITIAL WEIGHING UNIT SETTING 】

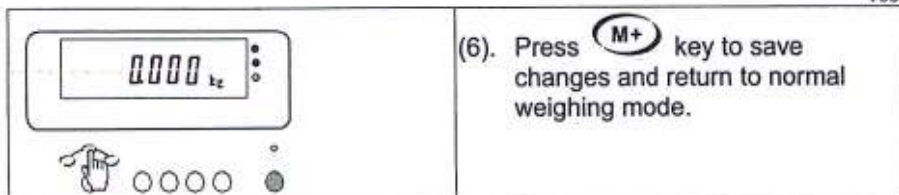

 <p>The diagram shows a scale display with '0.0 kg'. Below the display, a hand is shown pressing the 'UNIT' key, which is the second key from the left among four circular buttons.</p>	<p>(1). Press  key and turn of the scale at the same time. Display will show </p>
 <p>The diagram shows the same scale display with '0.0 kg'. A hand is shown pressing the 'UNIT' key again.</p>	<p>(2). Press  key for selection of different weighing unit, there are 4 weighing units : kg, lb, pcs, % .</p>
 <p>The diagram shows the scale display with '0.0 kg'. A hand is shown pressing the 'TARE' key, which is the rightmost key among the four circular buttons.</p>	<p>(3). Use  key to select the weighing unit to be ON (in used) or OFF (not in used)</p>
 <p>The diagram shows the scale display with 'Pran kg'. A hand is shown pressing the 'M+' key, which is the rightmost key among the four circular buttons.</p>	<p>(4). Press  key to save changes and display will now show  as the initial weighing unit.</p>
 <p>The diagram shows the scale display with 'Pran kg'. A hand is shown pressing the 'UNIT' key.</p>	<p>(5). Press  key to choose the desired Unit as the initial weighing unit when turn on the scale.</p> <p>Remark : The selected weighing unit must be ON(in used) when select for initial weighing unit</p>

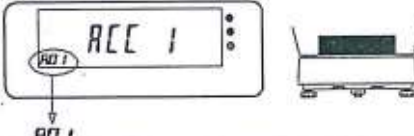

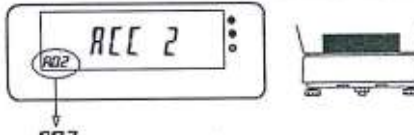
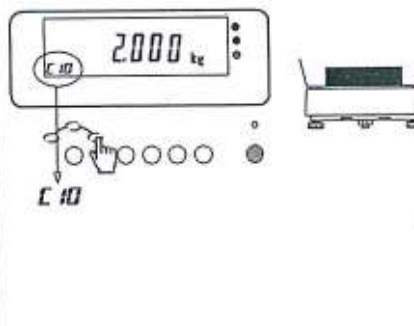
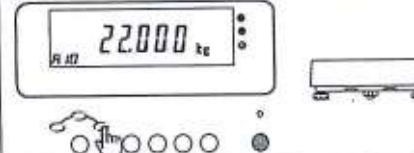

## 【 ACCUMULATIONS 】

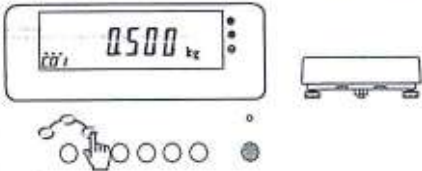
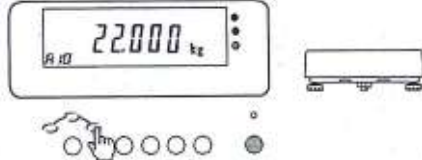
	<p>(1). Place an object on the pan wait for the stable sign and press <b>M+</b> key.</p>
	<p>(2). Display will show "ACC 1", and also the weight of the object. At the same time, you can see the sign "A01" on the operation message display.</p>
	<p>(3). Remove the first object and place the next object on the pan, press <b>M+</b> key when stable.</p>
	<p>(4). The display will show "ACC 2" and the weight of the second object. The sign "A02" will appear on the operation message display.</p>
	<p>(5). Repeat procedures (3) and (4), for the desired accumulations</p> <p>(6). Press <b>MR</b> key now, display will show the weight of the last object. The operation message display at left will show <math>\left[ \times \times \right]</math> (flashing). For example if there are 10 accumulations, it will show <math>\left[ C 10 \right]</math>.</p>
	<p>(7). Press <b>MR</b> key again and you will see all the 10 accumulations' total weight. <math>\left[ R 10 \right]</math> indicates all the 10 accumulations!</p>

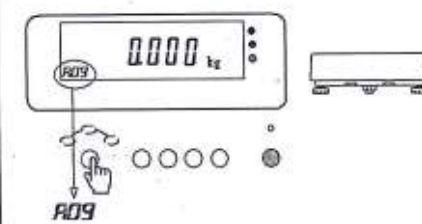

	<p>(8). Press <b>MR</b> <b>EN/DIS</b> key again, it will tell you the weight of the first accumulation. The operation message display will show <b>001</b>.</p> <p>One can also press <b>UNIT</b> <b>LOV</b> to move to last accumulation.</p>
	<p>(9). To delete accumulations, press <b>MR</b> <b>EN/DIS</b> key to recall the respective accumulation. For example <b>R 01</b> or <b>009</b>.</p>
	<p>(10). Press <b>M-</b> <b>S.NO</b> and when the display show <b>dEL-R</b> (meaning to delete all the accumulations) or <b>dEL-09</b> (to delete the respective accumulation). Press <b>M-</b> <b>S.NO</b> key to confirm delete</p>
	<p>(11). If all the accumulations are deleted, the display will return to normal weighing mode. When there is only one single accumulation that has been deleted, the small indication will blink and need to press <b>ZERO</b> <b>ESC</b> key to return to normal weighing mode.</p>
<p>Remarks :</p> <p>Maximum number of accumulation is 50 units.</p>	

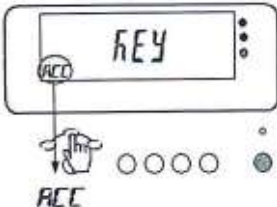
## 【 ACCUMULATION MODE SETTING 】

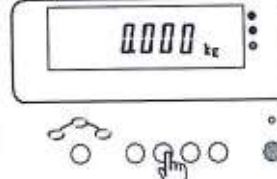
 <p>The diagram shows a scale display with 'KEY' and 'ACC' on the screen. A hand is shown pressing the 'M+' key on the control panel. Below the panel, the text 'ACC' is written.</p>	<p>(1). While the pan is empty press <b>M+</b> key, display show <i>KEY</i> and the operation message display show <i>ACC</i>.</p>
 <p>The diagram shows a scale display with 'STABLE' and 'ACC' on the screen. A hand is shown pressing one of the function keys on the control panel.</p>	<p>(2). Press <b>PRINT/HA</b> or <b>UNIT/LOV</b> key to select the accumulation mode. (refer to the below mentioned chart)</p>
 <p>The diagram shows a scale display with '0000 kg' and 'ACC' on the screen. A hand is shown pressing the 'M+' key on the control panel.</p>	<p>(3). Press <b>M+</b> key to complete the setting and return to normal weighing mode.</p>
<p>※ Accumulation mode</p> <p><i>KEY</i> : Accumulate manually by pressing <b>M+</b></p> <p><i>STABLE</i> : Accumulate when stable symbol appear</p> <p><i>oH</i> : Accumulate when weighing is between HI -LO checking limits. (this function is valid even if HI-LO checking function is disabled)</p>	

## 【 POSITIVE AND NEGATIVE FORMULA WEIGHING FUNCTION 】

- Advanced parameter "PF:" : the switch function of POSITIVE or NEGATIVE formula  
**PF: "OFF"**: positive and negative formula function is off  
**PF: "ON"**: The positive and negative formula function is on
- Advanced parameters "DE:" : the mode of removing accumulation data after finishing printing total amount of formula function.  
**"DE: MD1"**: press **M-** button to remove and return to the weighing mode;  
**"DE: MD2"**: automatically remove and return to the weighing mode.
- Increase the positive and negative formula function

### (1) Positive formula function

**a.** Press "**M+**" button to do accumulation when firstly put the load on the weighing pan. And printer will print date and time, Serial number 1, Weight; and then it will auto tare.

**b.** Then put the second load on the weighing pan and press "**M+**" button. The printer will print Serial number 2, Weight; and then it will auto tare.

Repeat step **b** to circulate accumulation; and will start from step **a** after removing all the accumulation data. Press "**MR**" after finishing accumulation to show total weight and printer will print Total, accumulation total weight.

**DE: MD1 mode:** press "**MR**" again to circularly show single value and the accumulative total weight. Press "**M-**" when displaying the accumulative total weight, it displays "**DEL - A**". Then press "**M-**" key to clear the accumulation values, and cancel tare.

**DE: MD2 mode:** remove all accumulated values and return to the weighing condition.

Printing sample is below:

```

2014-09-19 13:21:38
(1)      1.000 kg
(2)      0.100 kg
(3)      0.065 kg
(4)      0.999 kg
Total:   2.164 kg
  
```

### (2) Negative formula function

**a.** Press "**Tare**" key to do zero when firstly put the load on the weighing pan. Then take some weight out from the load on the weighing pan and press key "**M+**" to accumulate. Printer will print date and time, Serial number 1, Weight; and then it will auto tare.

**b.** Remove the surplus weight and put it on the weighing pan again. Press "**TARE**" to do zero. Take some weight out from the load on the weighing pan and press key "**M+**" to accumulate. Printer will print Serial number 2, Weight; and then it will auto tare.

Repeat step **b** to circulate accumulation; and will start from step **a** after removing all the accumulation data. Press "**MR**" after finishing accumulation to show total weight and printer will print Total, accumulation total weight.

**DE: MD1 mode:** the same as positive formula function

**DE: MD2 mode:** the same as positive formula function

Printing sample is below:

2014-09-22 08:36:45

(1) - 0.028 kg  
 (2) - 0.100 kg  
 (3) - 0.037 kg  
 (4) - 1.000 kg  
 Total: - 1.165 kg

Note: you need to set advanced parameter A21 as "PR: ALL" before doing negative formula function.

We take **Cheeses** for an example to do negative formula function:

**Step 1 operations (parameter setting):**

1. Long press **GROSS/NET** while turning on the scale (enter General Parameter Setting);
2. Long press **TARE** (enter Advance parameter setting menu);
3. Press **M-** or **M+** to step through each parameter, and press **HI** or **LO** to change parameter options.
4. Set **A07** (Min. Weighing Capacity) as 1-2 d if the items you weight is very small.
5. Set **A21** (weighing value range in printing pattern) as **PR: ALL** (Positive-zero-negative value are all available to print), but the printing format setting is unable.
6. Set **A27** (Positive and negative function) **ON/OFF** and you set to **ON**.
7. Set **A28** (Clear accumulation). Options are **DE: MD1** and **DE: MD2**. you choose one and press **GROSS/NET** twice to save and back to weighing condition.

**DE: MD1:** Press **MR** to show total values and then press it to show each accumulation values. Press **M-** twice to delete the displayed accumulation records by turns. After all the accumulation records are cleared, screen goes back to weighing mode.







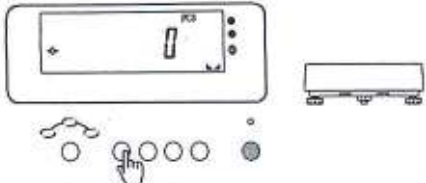

**DE: MD2:** Press **MR** to print total records and clear all the accumulation data at the same time.

**Step 2 operations (example display):**

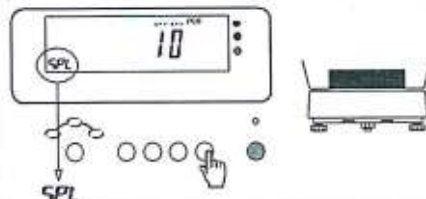

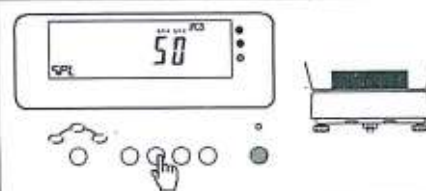

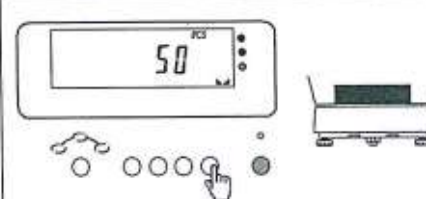

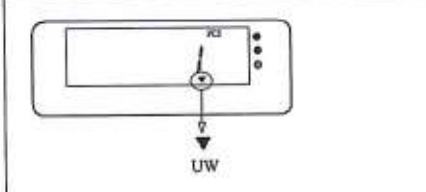

1. Press the cheese box on the weighing pan, press Key **TARE**, screen shows zero.
2. Take certain quantity of cheese from cheese box, screen shows the weight of cheese you take away. Press key **M+** to accumulate the displayed record.
3. Again take quantity of cheese from cheese box and press **M+**, just repeat this step till cheese box is empty.
4. **If A28 is set to MD1:** Press **MR** to see all the records you take from the cheese box. Press **M-** to delete records by turns.  
**If A28 is set to MD2:** Press **MR** to print total records and clear all the accumulation data at the same time.

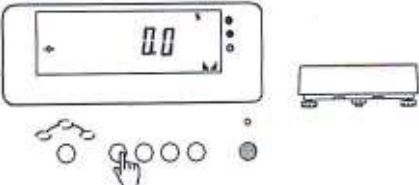
**Note:** **HI/LO** function only works with positive formula weighing function.

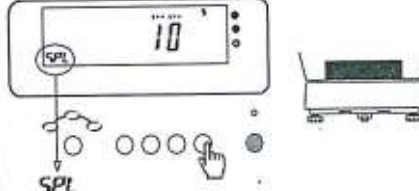
## 【 SIMPLE COUNTING 】

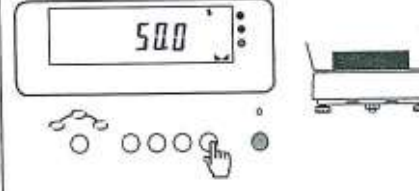

	<p>(1). Press  key to select the PCS as weighing unit.</p>
	<p>(2). Place the sampling quantity on the pan. (You can choose the sampling quantity as 10, 25, 50, 100PCS only!)</p>
	<p>(3). Press  key, display show the number of it as 10PCS (flashing) and the operation message display will show SPL.</p>
	<p>(4). Press  or  key to select the sampling quantity. For example, if you select 50pcs for sampling quantity 50pcs (flashing) will be displayed on the screen.</p>
	<p>(5). Press  key to complete the sampling procedures. Now the scale is ready for simple counting. Put the same objects on the pan for counting.</p>
	<p>Remarks : If the sampling quantity's unit weight for 1pcs is <math>\leq 0.8 \times</math> division, indication of insufficient unit weight will appear.</p>

## 【 PERCENTAGE % 】

	<p>(1). Press  key to select % as weighing unit .</p>
	<p>(2). Place the sampling quantity on the pan. (You can choose the sampling quantity as 10, 25, 50 or 100 %)</p>
	<p>(3). Press  key, display show the number of it as 10 % (flashing) and the operation message display will show SPL indicate now is in sampling mode.</p>
	<p>(4). Press  or  key to select the sampling quantity. For example, if you select 50 % for sampling quantity; 50 % (flashing) will be displayed on the screen.</p>
	<p>(5). Press  key to complete the sampling procedures. Now the scale is ready for simple percentage weighing. Put object on the pan for percentage weighing.</p>

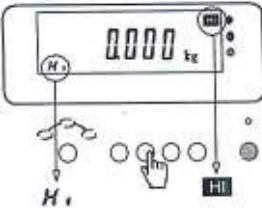
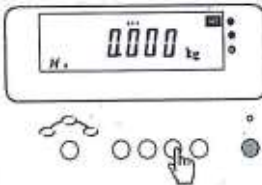
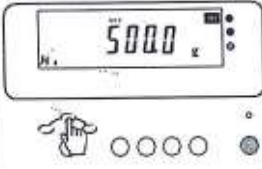
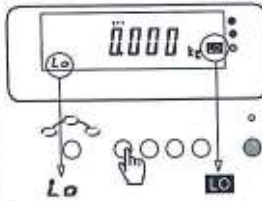
## 【 HI / LO Checking for weight 】

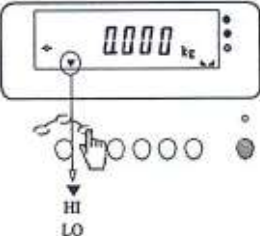
	<p>(1). Press <b>PRINT</b> key, indicator is ready for entering the value of the HI limit, the <b>HI</b> indication on the right will appear and the operation message display will appear <b>Hi</b></p> <p>Remark : If the parameter 3(P3) is not set as <b>no-LICE</b>, press <b>PRINT</b> for 3 seconds to set this function.</p>
	<p>(2). Press <b>TARE</b> key to move the cursor to the digit you want to change.</p>
	<p>(3). Press <b>M+</b> or <b>M-</b> key to enter the number.</p> <p>(4). Repeat (2), (3) to complete the setting of HI limit.</p>
	<p>(5). Press <b>UNIT</b> key, indicator is ready for entering the value of the LO limit, the <b>LO</b> indication on the left will appear and the operation message display on the left will show <b>Lo</b>.</p> <p>(6). Repeat (2), (3), (4) to complete the setting of LO limit.</p>

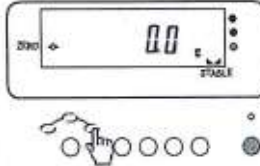
 <p>The diagram shows a scale's LCD display with '0000 kg' and a small arrow pointing left. Below the display is a keypad with five circular buttons and a larger circular button on the right. A hand is shown pressing the first button. Below the keypad, the letters 'HI' and 'LO' are printed with arrows pointing downwards.</p>	<p>(7). Press <b>MR</b> <b>EN/DIS</b> key to enable the checking function and the scale returns to the normal weighing mode. The arrow pointing to HI, LO will appear and the HI, LO function is ready for operation.</p>
 <p>The diagram shows the scale's LCD display with '5000 g'. Below the display, the letters 'HI' and 'LO' are visible. The keypad below has five circular buttons and a larger circular button on the right. A hand is shown pressing the second button.</p>	<p>(8). To cancel the function of HI-LO checking, press <b>PRINT</b> <b>MR</b> key when the indication of HI-LO indication signs is on the LCD.</p>
 <p>The diagram shows the scale's LCD display with '00'. To the left of the display is the word 'ZERO' and to the right is 'STABLE'. Below the display is the keypad with five circular buttons and a larger circular button on the right. A hand is shown pressing the first button.</p>	<p>(9). Followed by pressing <b>MR</b> <b>EN/DIS</b> key . HI, LO indication signs will disappear and this function is disabled.</p> <p>Remarks : LO limits must be <math>\leq</math> HI limits</p>





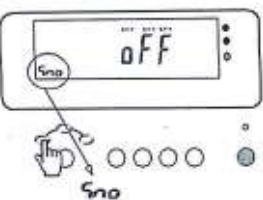
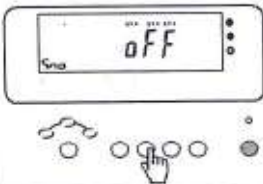
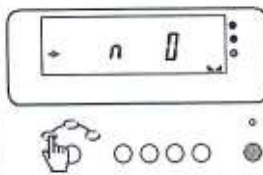

## 【SERIAL NUMBER】

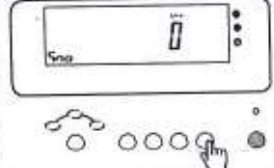
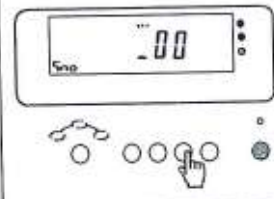
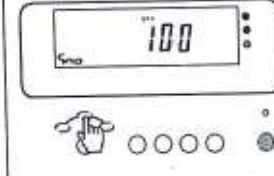
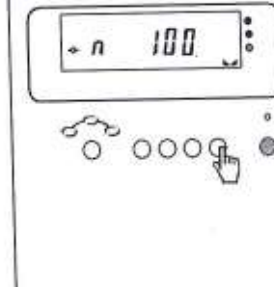
	<p>(1). Press <b>M-</b> <small>S.NO</small> key display will show <i>OFF</i> (flashing) and operation message display will show <i>S.NO</i>.</p>
	<p>(2). Press <b>PRINT</b> <small>HI A</small> or <b>UNIT</b> <small>LO V</small>, to select the desired serial number mode. Please refer to below diagram.</p>
	<p>(3). After select, press <b>M-</b> <small>S.NO</small> key to return to weighing mode, display will now show <i>n</i> <math>\bar{\bar{}}</math> for serial number, except if the setting is in <i>OFF</i> mode.</p>
<p>※ Mode of serial number :</p> <ul style="list-style-type: none"> <li><i>OFF</i> : No action.</li> <li><i>SETABLE</i> : The serial number plus 1 (+1) when the stable sign appear.</li> <li><i>ON</i> : Serial number plus 1 (+1) when the weights is in between HI-LO checking limits this function is valid even if the HI-LO checking function is disabled.</li> <li><i>STOP</i> : Pause! No adding of serial number but display will still show the last serial number when there is nothing on the pan.</li> </ul>	

## 【 STARTING SERIAL NUMBER SETTING 】

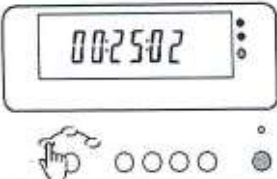
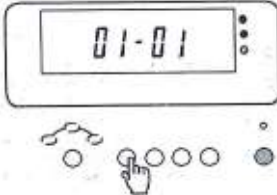

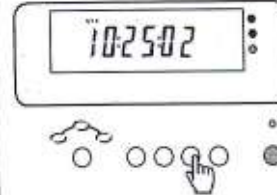
	<p>(1). Under normal weighing mode</p> <p style="text-align: center;"><b>M-</b></p> <p>press <b>S.NO</b> key, display will show the current mode of series number, for example :</p> <p style="text-align: center;"><b>Sno SERBLE</b></p>
	<p style="text-align: center;">FUNC <math>\Delta</math></p> <p style="text-align: center;"><b>GROSS NET</b></p> <p>(2). Press <b>GROSS NET</b> key, display will show</p> <p style="text-align: center;"><b>Sno 0</b></p>
	<p>(3). Press <b>TARE</b> key to move the cursor to selected digit for change. Example : Serial number starting from 100, then move the cursor to</p> <p style="text-align: center;"><b>Sno 00</b></p>
	<p>(4). Press <b>M+</b> or <b>S.NO</b> key to key in the number. Example : 100 is the starting serial number</p> <p style="text-align: center;"><b>Sno 100</b></p>
	<p style="text-align: center;">FUNC <math>\Delta</math></p> <p style="text-align: center;"><b>GROSS NET</b></p> <p>(5). Press <b>GROSS NET</b> key to save the changes and return to normal weighing mode.</p> <p>Now the starting serial number is 100</p> <p>Remarks : Max. serial number is 99999 .</p>

## 【 TIME SETTING 】

	<p>(1). Under normal weighing mode</p> <p style="text-align: center;"><b>M-</b></p> <p>press <b>s.NO</b> key for 3 seconds and display will show the time.</p>
	<p>(2). Press <b>PRINT HIA</b> or <b>UNIT LOY</b> to switch to DATE / MONTH or YEAR display.</p> <p>Remark : To escape press <b>ZERO ESC</b> or <b>M-</b> s.NO</p>
	<p>(3). Press <b>GROSS NET</b> key to enter to time setting mode. Last digit is flashing.</p>
	<p>(4). Press <b>TARE</b> key to move the cursor and press <b>M+</b> or <b>M-</b> s.NO key to change the digits.</p> <p>Remark : Now can also press <b>PRINT HIA</b> or <b>UNIT LOY</b> and switch to setting of DATE / MONTH or YEAR.</p>
	<p>(5). Press <b>GROSS NET</b> key to complete the setting and display the current TIME.</p> <p>(6). Press <b>ZERO ESC</b> to return to normal weighing mode.</p>



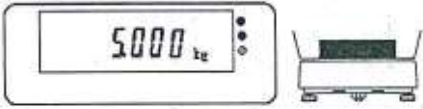
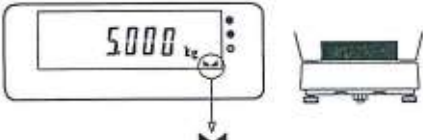
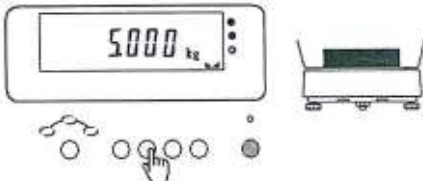



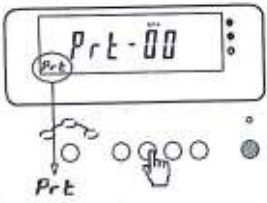

	Remarks : After switching off the indicator, the date/time will be erased unless if this indicator is equipped with RTC + Rs232.
--	--

## 【 PRINT 】

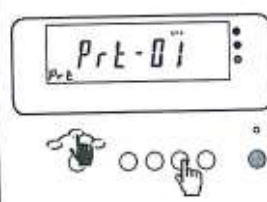
	(1). Place the object on the pan.
	(2). Wait for the stable symbol.
	<p>(3). Press  to print.</p> <p>Remarks : This function is workable only with the purchased of RS-232 interface and compatible printer.(P3 should also be set to compatible printer)</p>



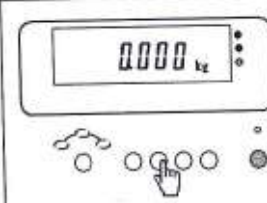



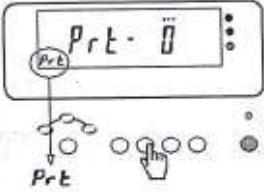

## 【 PRINT FORMAT SETTING 】

This function is applicable only when the Parameter P3 - Printer Type is set to normal , SH-24 , BP-443D , EZ-2PZEBRA or GODEX.

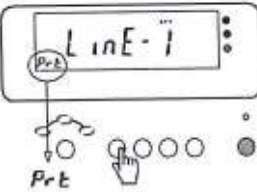
 <p>The diagram shows a scale display with 'Prt-00' and a hand pressing the 'Prt' key. Below the display are four circular buttons and a power button.</p>	<p>(1). Under normal weighing mode press  key when the pan is empty. Display <i>Prt-00</i>, (flashing) and the operation message display will show <i>Prt</i>.</p> <p>Remark : If P3 was set to <i>no-use</i>, the scale will then enter to HI limit setting.</p>
 <p>The diagram shows the scale display with 'Prt-01' and a hand pressing the 'TARE' key. Below the display are four circular buttons and a power button.</p>	<p>(2). Press  key to move the cursor and use  or  key to key in number. In total there are 100 print format available for choose.</p>
 <p>The diagram shows the scale display with '0000 kg' and a hand pressing the 'PRINT' key. Below the display are four circular buttons and a power button.</p>	<p>(3). Press  key to complete the chosen and return to normal weighing mode.</p>
<p>Note :</p> <ol style="list-style-type: none"> <li>There are six options of printers available : SH-24( dot-matrix printer), SH-16, BP-443D( Label printer ), EZ-2P(Label printer), ZEBRA (Label printer), GODEX (Label printer) or GP(Label printer).</li> </ol>	

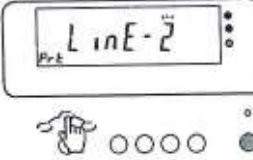
# 【 SPACE BETWEEN LINES WHEN PRINTING 】

Only available for SH24 / SH-16/normal

	<p>(1). In parameter for printer(P3) choose the setting to SH-24 / NORMAL.</p>
	<p>(2). While the pan is empty press  key and display shows <i>PrE-0</i>. The operation message display will show <i>PrE</i>.</p>
	<p>(3). Press  key, display show <i>LINE-1</i>. The operation message display will show <i>PrE</i>.</p>
	<p>(4). Press  or  key to set the number of empty lines (space) when printing. {minimum =0, maximum=9}</p>
	<p>(5). Press  key to complete the setting and return to normal weighing mode.</p>

## 【 PRINTING MODE SETTING 】

\* This function is applicable only when the Parameter P3 - Printer Type is set to normal, SH-24 , BP-443D , or EZ-2P.

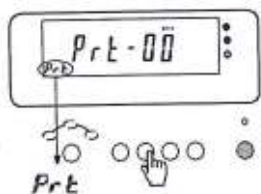

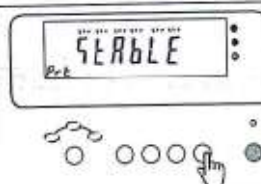

- (1). Press  key. Display show *Prt-00*, operation message display show *Prt*.

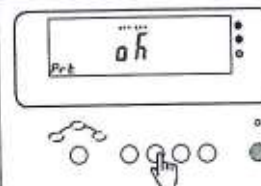

- (2). Press  key. Display will show the printing mode.  
Example : *5tRbLE*



- (3). Use  or  key to select the printing mode. (refer to the below mentioned chart)

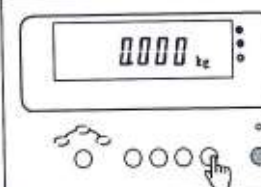

- (4). Press  key to save changes and return to normal weighing mode.

- KEY** : Print manually by pressing PRINT key.
- Conti n** : Print continuously when connecting to PC or large LED Display.
- 5tRbLE** : Print after stable symbol appear
- oH** : Print when weight is between HI-LO limits (this function is valid even if HI-LO checking function is disabled)

# [ SAMPLES OF BP-443D/ EZ-2P/ZEBRA/GODEX PRINTING FORMAT ]

prt-00

2004/11/25 12:27:58  
**N.W. : 1.000 kg**  
**T.W. : 0.500 kg**  
**G.W. : 1.500 kg**

prt-05

Tw: 0.500 kg GW: 1.500 kg  
**1.000 kg**  
 2004/11/25 12:29:04  
 rate  1  2  3

prt-01

2004/11/25 12:28:11  
**1.000 kg**  
 ABC COMPANY  
 0981-123456

prt-06

Tw: 0.500 kg GW: 1.500 kg  
**1.000 kg**  
 2004/11/25 12:29:14

prt-02

2004/11/25 12:28:26  
**1.000 kg**

prt-07

Tw: 0.500 kg GW: 1.500 kg  
**1.000 kg**  
 2004/11/25 12:29:39

prt-03

2004/11/25 12:28:26  
**N.W. : 1.000 kg**  
**T.W. : 0.500 kg**  
**# 0**

prt-08

2004/11/25 12:29:30  
**1.000 kg**  
**# 0**

prt-04

2004/11/25 12:28:50  
**1.000 kg**

prt-09

**N.W. 1.000 kg**  
**T.W. 0.500 kg**  
**G.W. 1.500 kg**

\* 10 Print formats are preset in printer by Jadever \*

- Note : (1) Please contact your supplier/-dealer for additional EZ-2P/ZEBRA, GODEX /BP-443D print formats.
- (2) A memory card has to be installed in EZ-2P.  
 (BP-443D), ZEBRA, GODEX memory card is standard)
- (3) The print formats are installed into the printers through PC. Please email your specific requirement to us and we will make the requested print format for you.



# 【 SAMPLES OF SH-24 PRINTING FORMATS 】

When **ALL03** appear under display of accumulation,

press  key the print-out will like as following.

Prt-00	0.379kg
Prt-01	2002/01/01 00:09:23 0.379kg
Prt-02	#1 0.379kg
Prt-03	2002/01/01 00:09:23 #1 0.379kg
Prt-04	N.W: 0.379 kg T.W: 0.100 kg G.W: 0.479 kg
Prt-05	2002/01/01 00:09:23 N.W: 0.379 kg T.W: 0.100 kg G.W: 0.479 kg
Prt-06	#1 N.W: 0.379 kg T.W: 0.100 kg G.W: 0.479 kg
Prt-07	2002/01/01 00:09:23 #1 N.W: 0.379 kg T.W: 0.100 kg G.W: 0.479 kg

2002/01/01 00:09:23:

(1) 0.100 kg

(2) 0.100 kg

(3) 0.100 kg

-----  
0.300 kg







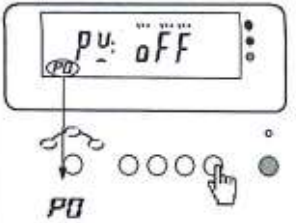

## 【 Samples of SH-16 Printing Formats 】

<p>Prt00: 0.500 kg</p> <p>Prt01: 2002/01/01 00:01:25 0.500 kg</p> <p>Prt02: #0 0.500 kg</p> <p>Prt03: 2002/01/01 00:01:42 #0 0.500 kg</p> <p>Prt04: G.W.: 1.000 kg T.W.: 0.500 kg N.W.: 0.500 kg</p> <p>Prt05: 2002/01/01 00:02:09 G.W.: 1.000 kg T.W.: 0.500 kg N.W.: 0.500 kg</p> <p>Prt06: #0 G.W.: 1.000 kg T.W.: 0.500 kg N.W.: 0.500 kg</p> <p>Prt07: 2002/01/01 00:02:25 #0 G.W.: 1.000 kg T.W.: 0.500 kg N.W.: 0.500 kg</p> <p>Prt08:</p> <hr style="border: 0.5px solid black;"/> <p>Prt09: 2002/01/01 00:07:29 (1) 0.500 kg (2) 0.500 kg (3) 0.500 kg</p> <hr style="border: 0.5px solid black;"/> <p style="text-align: center;">1.500 kg</p> <p>Note: Supposed that it is tare weight</p>	<p>Prt00: 0.500 kg</p> <p>Prt01: 2002/01/01 00:01:25 0.500 kg</p> <p>Prt02: #0 0.500 kg</p> <p>Prt03: 2002/01/01 00:01:42 #0 0.500 kg</p> <p>Prt04: 0.500 kg</p> <p>Prt05: 2002/01/01 00:02:09 0.500 kg</p> <p>Prt06: #0 0.500 kg</p> <p>Prt07: 2002/01/01 00:02:25 #0 0.500 kg</p> <p>Prt-08</p> <hr style="border: 0.5px dashed black;"/> <p>Prt-09 2002/01/01 09:20:45 Note: Supposed that it is not tare weight</p>	<p>When <b>NO</b> appear under display of accumulation,</p> <p style="text-align: center;">  </p> <p>press <b>PRINT</b> key the print-out will like as following.</p> <div style="text-align: center; margin-top: 20px;"> <p>2002/01/01 00:09:23</p> <p>(1) 0.100 kg</p> <p>(2) 0.100 kg</p> <p>(3) 0.100 kg</p> <hr style="width: 50%; margin: 0 auto;"/> <p>0.300 kg</p> </div>
---	---	--

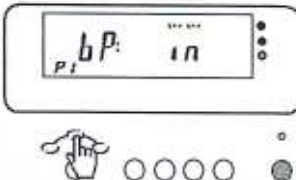

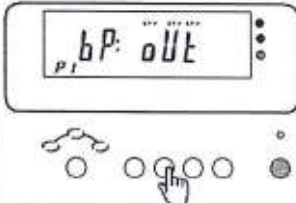
Remark :

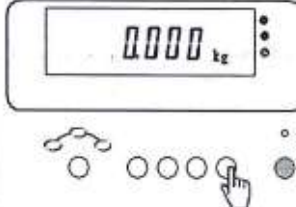
Without any commands, the printer are able to print format Prt00~Prt07 when connected to a parallel port printer.

## 【 PARAMETER SETTING 】



 <p>The display shows 'PU: OFF' with 'PD' indicated below the 'PU'. On the control panel, the first button is highlighted with a hand icon, and the label 'PD' is written below it.</p>	<p>(1). Press  key and turn on the scale or under normal weighing mode, press  key for 3 seconds. Display will show <i>PU: "OFF"</i> and operation message display show <i>PD</i>.</p>
 <p>The display shows 'bP: in' with 'P1' indicated below the 'bP'. On the control panel, the second button is highlighted with a hand icon.</p>	<p>(2). Use  or  key to select the parameter (refer to the chart below).</p>
 <p>The display shows 'bP: OUT' with 'P1' indicated below the 'bP'. On the control panel, the third button is highlighted with a hand icon.</p>	<p>(3). Use  or  to change the setting of each parameter.</p>
 <p>The display shows '0000 kg'. On the control panel, the first button is highlighted with a hand icon.</p>	<p>(4). Press  key to save changes and return to normal weighing mode.</p>

## 【 EXPLANATION OF PARAMETERS 】

No	Function	Display	Detail
P0	Auto Power Off (weights < 20d )	OFF	Off ( No action )
		5	5 minutes
		10	10 minutes
		30	30 minutes
		☆ 60	60 minutes
		90	90 minutes
P1	Beeping (The effect of this parameter is to determine when to have beep sounds during HI/OK/LO checking.)	☆ 1n	Scale : Enable the HI-LO checking functions , beeps when the range is between HI & LO
		OUT	Scale : Enable the HI-LO checking functions, beeps when the range is out of HI & LO
		En	Option : Relay with light tower : beeps when the range is between HI & LO
		EOUT	Option : Relay with light tower : beeps when the range is out of HI & LO
P2	HOLD (able to hold the displayed weight after load is remove)	☆ OFF	No action of Hold
		on	Able to hold the displayed weight and print at the same time after pressing print key  ( when there is loading ). Press key  to clear. *This function will work only when P3-Printer Type is set as NORMAL or SH-24, SH-16, zebra, bp-443, et, godex, cx, ez-2p.
P3	Printer type Setting of this parameter determines the data format for the connected printer type	☆ no-use	No connection to any printer
		normal	English font
		U-key	U.KEY connector, which could works with PC and outputs the weighing data to PC in form of Excel, ERP and so on.
		SH-24	Normal dot-matrix printer
		SH-16	Normal dot-matrix printer

		RE	English font
		6P-443	Label Printer
		E7-2P	Label Printer
		2EbrR	Label Printer
		6odE3	Label Printer
		E4	Large LED display
		E3	Large LED display
P4	RS-232 Baud Rate Setting of this parameter determines RS-232 data transmission rate.	2400	
		4800	
		☆ 9600	
		19200	
P5	RS-232 Data Format Setting of this parameter determines the RS-232 transmission data format.	☆ n81	
		o81	
		E81	
		n71	
		o71	
P6	Backlight	oFF	No Backlight
		on	Backlight is on always
		☆ 5RuE	Off automatically 5 seconds after stable weighing
		Auto	Auto (backlight is actuated when weight loading is over 20d)

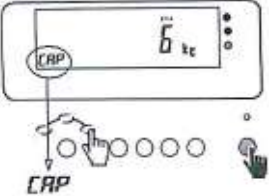
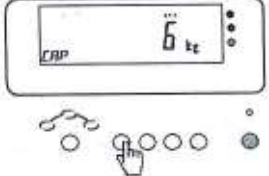
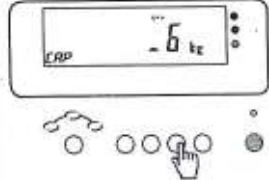
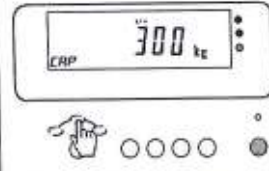
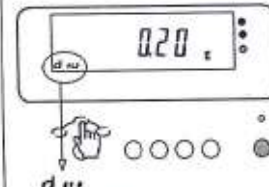
# 【 CAPACITY / RESOLUTION SETTING 】

	<p>(1). Press <b>MR</b> key and turn on the scale. Display will show capacity of the scale (flashing), operation message display will show <b>CAP</b></p>
	<p>(2). If to use low capacity such as 600g or use lb as unit, press <b>UNIT</b> key to select the weighing unit as g or lb.</p> <p style="text-align: center;">kg ↓ g ↓ lb</p>
	<p>(3). Use <b>TARE</b> key to move the cursor to the digit which needs to be change.</p> <p style="text-align: center;"><b>CAP</b> 6 kg</p>
	<p>(4). Press <b>M+</b> or <b>S.NO</b> key to enter the desired capacity and complete the setting</p> <p style="text-align: center;"><b>CAP</b> 300 kg</p>
	<p>(5). Press <b>MR</b> key and enter into setting of resolution mode. Display will show the resolution (flashing) and operation message display will indicate <b>d.u</b> symbol.</p>
	<p>(6). Repeat steps (3), (4) to complete setting of resolution.</p> <p style="text-align: center;"><b>d.u</b> 2000 g</p>

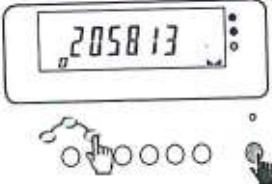

(7). Press **MR** EN/DIS key and display will show the internal self checking value and stop. This means that setting of capacity/resolution is completed.

Example : 

Turn off the scale and turn on again.

Note :

Maximum capacity to be set for this indicator is 400000kg.

Minimum division to be set for this indicator is 0.01g.

Whenever the capacity / resolution is set or changed, be sure to re-calibrate according to calibration procedure on service manual.

## 【 DIVISION CONFIGURATION CHART 】



	Kg		g		lb
Max	5000kg	Max	5000g	Max	500lb
	2000kg		2000g		200lb
	1000kg		1000g		100lb
	500kg		500g		50lb
	200kg		200g		20lb
	100kg		100g		10lb
	50kg		50g		5lb
	20kg		20g		2lb
	10kg		10g		1lb
	5kg		5g		0.5lb
	2kg		2g		0.2lb
	1kg		1g		0.1lb
	0.5kg		0.5g		0.05lb

0.2kg	0.2g	0.02lb
0.1kg	0.1g	0.01lb
0.05kg	0.05g	0.005lb
0.02kg	0.02g	0.002lb
0.01kg	0.01g	0.001lb

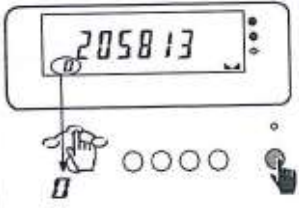
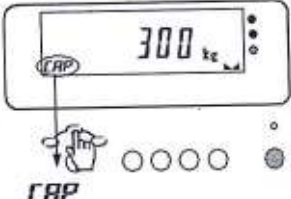
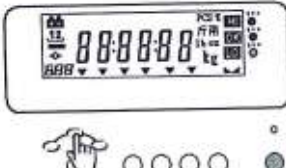
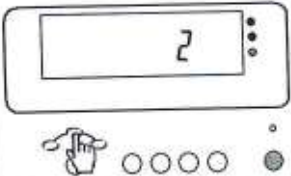
## 【 TESTING MODE 】











	<p>(1). Press <b>M+</b> key and turn on the scale. Display will show the internal count value and operation message display show <b>0</b>.</p>
	<p>(2). Press <b>M+</b> key, display will show the setting of capacity, the operation message display will show <b>CAP</b>.</p>
	<p>(3). Press <b>M+</b> key and all segments in display are appearing. This is to check if the display is in good condition.</p>
	<p>(4). Press <b>M+</b> key, display show <b>2</b>, this is to check the key function condition.</p>



	(5). After testing completed press  key to switch off.								
※ Relative position: <table style="width: 100%; border: none;"> <tr> <td style="width: 50%;">1 : Memory Cancel</td> <td style="width: 50%;">5 : Unit</td> </tr> <tr> <td>2 : Accumulation</td> <td>6 : Print</td> </tr> <tr> <td>3 : Zero / Esc</td> <td>7 : Tare</td> </tr> <tr> <td>4 : Memory recall</td> <td>8 : Gross / Net</td> </tr> </table>		1 : Memory Cancel	5 : Unit	2 : Accumulation	6 : Print	3 : Zero / Esc	7 : Tare	4 : Memory recall	8 : Gross / Net
1 : Memory Cancel	5 : Unit								
2 : Accumulation	6 : Print								
3 : Zero / Esc	7 : Tare								
4 : Memory recall	8 : Gross / Net								

## 【ERROR MESSAGES】

Error Message	Reasons / Possible Caused	Solutions
E0 <i>no EE</i>	The CPU unable to read the EEPROM	Contact the manufacturer or nearest agent
E1 <i>[RL-d]</i>	Unable to read the 3 points calibration range	Refer to "service manual" for calibration procedures
E2 <i>PHi</i>	<b>Zero Point is too high</b>	(1) Make sure the pan is empty when turn on the scale or perform the 3 points calibration. (2) Check the connections of wires
E3 <i>PLo</i>	Zero Point is too Low	(1) Make sure the pan is on the scale or perform the 3 points calibration. (2) Check the connections of wires.
E4 <i>UnSER</i>	Unstable zero point	(1) Make sure there is no winds or vibration . (2) Check the connections of wires.
E5 <i>LE-of</i>	(1)Load cell spec. not compatible. (2)calibrating weights mistake	(1) Replace with a compatible load cell. (2) Change with correct calibrating weights.
E6 <i>no LE</i>	Load cell read out always the same	(1)Check if load cell wire are connected correctly.

E7 <i>au-20</i>	The last accumulation is more than the preset accumulation allowed.	Press  key twice to clear all the accumulation or press  key to return to normal weighing mode.
E8 <i>LL-aut</i>	(1). Load cell specification is out of the ADC range (2). Wrong setting for calibration	(1). Choose the compatible load cell. (2). Re-calibrate the scale.
E10 <i>LLH-b</i>	Optional RS-232(RTC) batteries run out	Replace the batteries
E11 <i>diFF</i>	Unable to accumulate. Two objects are with different units.	Press  twice to clear all accumulation data or press  and return to normal weighing mode.
E12 <i>au-XX</i>	Accumulation data exceed preset maximum	Press  twice to clear all accumulation data or press  and return to normal weighing mode.
E13 <i>LoHi</i>	Hi / Lo setting incorrect	Press  key and reset Hi / Lo value.
E20 <i>XXXXX</i>	External division over Maximum (XXXXX is external resolution)	Press  and reset Capacity / Resolution
E21 <i>duL XX</i>	Capacity / Resolution Setting inaccurate.	Press  and redo Calibration (make sure the calibrate weight is correct).
-----	Overload (Maximum display= max .capacity + 9e )	Remove the object from the weighing pan.
	Indicator unable to Switch On when pressing  key	Use a tool to press the RESET key located at the back of the indicator to turn on the scale and clear the problem.

## 【 LCD CHARACTERS 】

0	1	2	3	4	5	6	7	8	9			
0	1	2	3	4	5	6	7	8	9			
A	B	C	D	E	F	G	H	I	J	K	L	M
A	b	C	d	E	F	G	H	i	J	k	L	m
N	O	P	Q	R	S	T	U	V	W	X	Y	Z
n	o	p	q	r	s	t	u	v	w	x	y	z

## 【 CONNECTER 】

Scale To Printer

Connector for BP343/EZ-2P/ZEBRA/GODEX

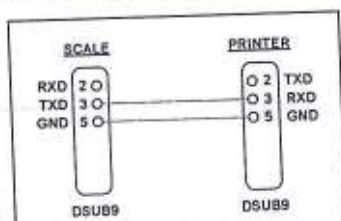

Connector for SH-24

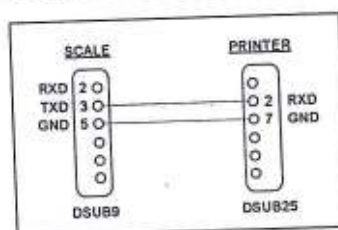

Scale To PC

When you want a scale to transmit data to PC continuously.

- (1) Using a cable as following to connect Scale and PC
- (2) Set **printer mode** as continue
- (3) Scale data will be sent to PC continuously. (of course, you must have the receiving software on the PC)

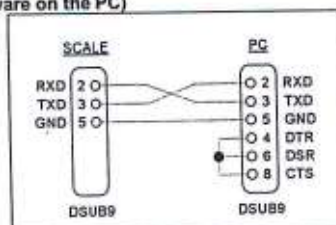

Only pin 2,3 and 5 are used.

## 【DATA PROTOCOL】

### ● Output Data when Print Mode set as Continue

( header1: ST=STABLE      US=UNSTABLE)  
 ( header2: NT=NET        GS=GROSS)

For example : ST /NT □ + □ 12.350 □ kg

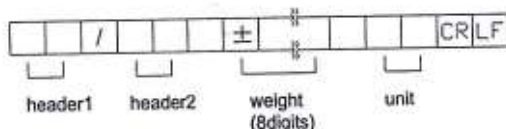

### ● Input commands

"T" = perform TARE function

"Z" = perform ZERO function

connect to AC and its transmitting form:

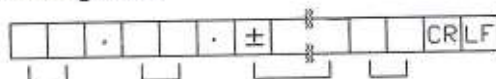

header1    header2    weight    unit  
 (8digits)

( header1: ST=STABLE      US=UNSTABLE)  
 ( header2: NT=NET        GS=GROSS)

For Example: ST, NT, +012.350kg

ST, NT, +012.350 □ g

# [ RELAY MODULE DIAGRAM ]

## ■ Relay Output :

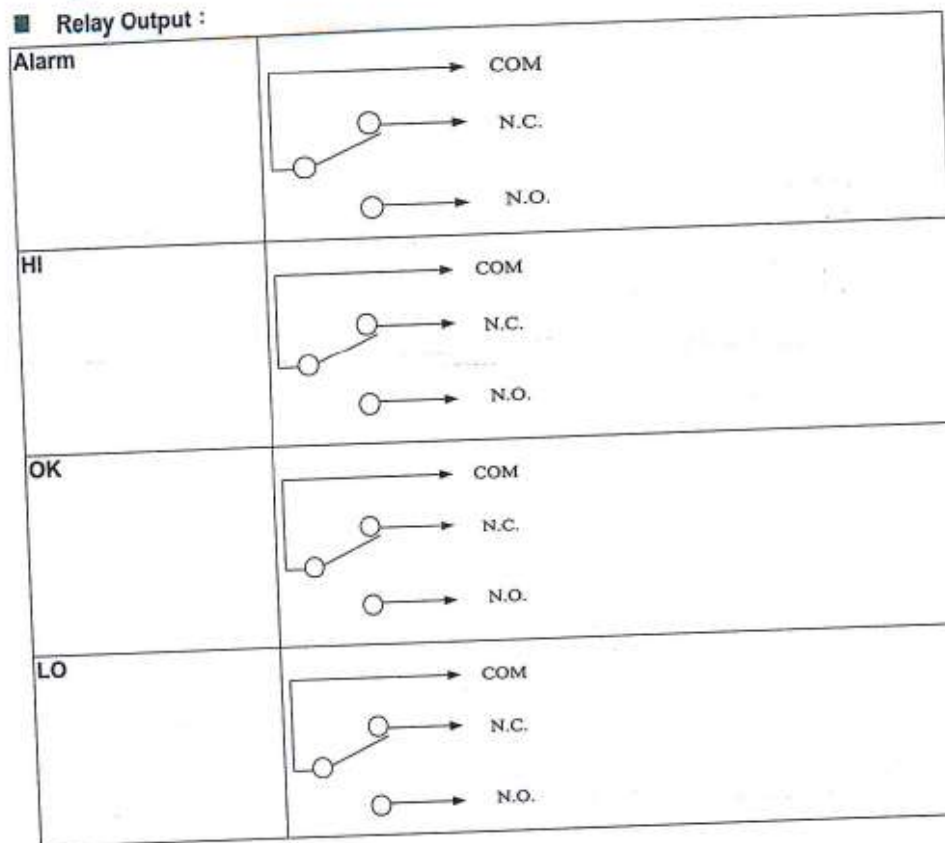

## ■ Relay Contact Spec

1A/24VDC, 0.5A/125VAC, 0.25A/250VDC

# 【PRODUCT SPECIFICATIONS】

## 1. General

Enclosure	ABS	S/S
Dimensions	230(W) * 150(H) * 90(D) mm	
Display	6digit 30mm(H) & 3digit 10mm(H) LCD(include EL backlight)	
Units	kg or g , lb , pcs , %	
Power	Adaptor 9V/1A Recharging Battery 6V/3Ah	Adaptor 9V/1A Recharging Battery 6V/3Ah can be selected
Weight(include Battery)	Approx. 2.5kg	Approx. 2.8kg

## 2. ADC and Loadcell

Model		Advanced
ADC	Transform Mode	$\Delta - \Sigma$
	Internal Resolution	Approx. 5,000,000 counts
	External Resolution	Max. 6,000d(OIML) Max. 60,000d(non-OIML)
	Conversion Speed	10 times/sec
System Linearity		Within 0.01% of FS
Loadcell	Excitation	5VDC $\pm$ 6%, 120mA (drives up to 8 * 350 L.C. )
	Full Scale	-10 ~ 40mV(include dead load)
	Input Sensitivity	Min. 0.7uV/d

# [ASSEMBLY MANUAL OF JIK INDICATOR AND SUPPORT STAND]

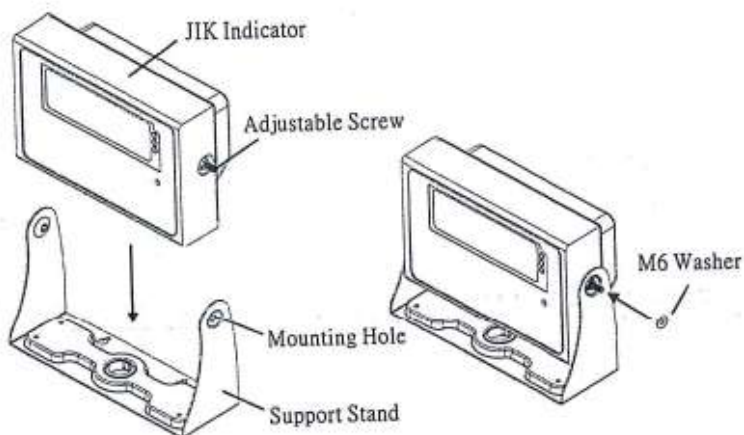

Illustrator I

Illustrator II

1. Using adjustable screw to pass through mounting hole. (illustrator I)
2. Put M6 washer onto adjustable screw. (illustrator II)

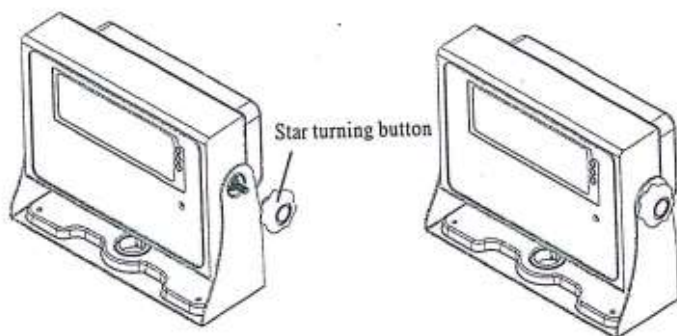

Illustrator III

Illustrator IV

3. Rotating the star turning button into adjustable screw. (illustrator III)
4. Adjust the indicator to the best view, and then rotate it tight via star turning button. (illustrator VI)

# 【 FIXING SCREW INSTRUCTION FOR JIK 】

## Stainless Steel Series

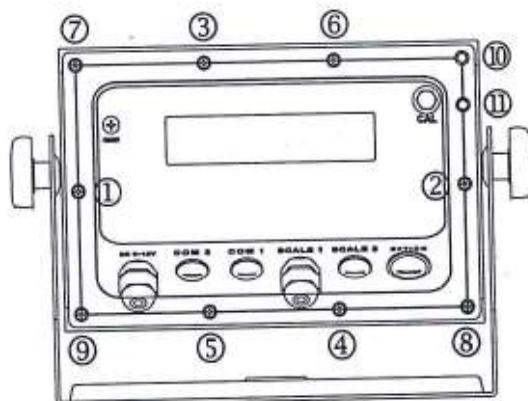

- After connecting load cell and optional devices (RS-232, RELAY), fix all screws attached follow the above numeric sequence.
- If using an electric screwdriver, set the torque range to 5-6 kgf.cm.
- Sealing screws are to be located at sequence CAL and 11.

## ABS Series

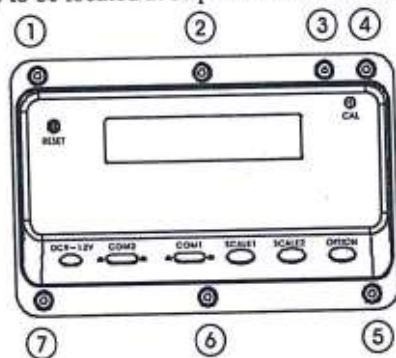



- Sealing screws are to be located at sequence CAL and 4.
- Grounding wire to be connected on position 3.



# 【 SINGLE POINT CALIBRATION FOR WEIGHT 】

## Step I (Enter into calibration mode)





Turn on the scale by holding down  key until CAP is shown on the lower left screen, i.e. the scale has entered into the calibration mode.

**Note:** If the calibration unit, capacity, and resolution have been set, you may skip Steps II-IV and press  key to enter into Step V to perform zero point calibration.





## Step II (Select Calibration Unit)

You may select calibration unit (kg, g) by use of  key.

## Step III (Capacity Setting)

Press  key and the flickering digit will shift to the right; press ,  key to set any value between 1-9; after setting, press  key to enter into the next step.

## Step IV (Resolution Setting)

Press  key and the flickering digit will shift to the right; press ,  key to set any value between 1, 2, 5; after setting, press  key to save and show the offset-value; press the weighing pan gently, if the value changes, it's normal.

## Step V (Zero Point Calibration)





Press  key to perform zero point calibration; when CAL on the lower left stops flickering, zero point calibration is completed with CAL \*\*kg shown.

**Note:** If the show value is very unstable, press  key to enter into stb adjustment function,

use  key to extend the range of stb (it is recommended to adjust one segment each



time), after confirmation, press  key to save setting and the zero point calibration will be performed automatically.



**Step VI (Single-point Calibration) Note: If to perform three-point calibration, skip this step.**

Press  key and the flickering digit will shift to the right; press ,  to adjust the value; input the weight value to be calibrated, and put the correct weight onto the weighing pan, then press  key to save and confirm, once PASS is shown, take away the weight on the weighing pan and restart the machine for normal use.

**Step VII (Three-point Calibration)**

Press  key for 3 seconds until C-1 is shown at the lower left corner.

**First Point C-1:** Press  key and the flickering digit will shift to the right; press ,

 key to set values; input the weight value to be calibrated, and put the correct weight onto the weighing pan, press  key to confirm and perform calibration.

**Second Point C-2:** Put the weight to be calibrated onto the weighing pan, the weight value will be shown automatically on the screen; press  key to confirm and perform calibration.

**Third Point C-3:** Put the weight to be calibrated onto the weighing pan, the weight value will be shown automatically on the screen; press  key to confirm and perform calibration. Once PASS is shown, take away the weight on the weighing pan and restart the machine for normal use.

Recalibration: If any error occurs during calibration, press  key to return to zero point calibration mode and perform calibration according to the calibration procedures.

Note: The weight value in three-point calibration shall comply with  $C-1 < C-2 < C-3$ .