

USER MANUAL

JC CRANE SCALE

Please read the manual carefully
before operating the scale.



Contents

Table of Contents

1.Overview	1
2.Features & Specifications	1
3.Keypad Operation	2
4.General Scale Operations	3
5.Battery Charging	3
6.Precautions	4
7.Calibration Method	4
8.Functions Setup in Sub-Menu	5
9.Schematics	6
10.Key pad functions of remote control	8
11.Error Information	8

■ *Overview*

JC series crane scale combines reliable, advanced electrical hardware with good software. Using AT series micro-processor and high speed, high precision A/D conversion technology, The JC series of scale has a specially designed jittering compensation circuitry, so they can reach steady state quickly with strong anti-interference capability. This series of scales can be used for weighing application in commercial trade, mines, storage and transportations.

■ *Features & Specifications*

Product Execute Standard	GB/T11883-2002
Accuracy Grade	III
Zero Range	100% Full Scale
Time to Stable Reading	<10 Seconds
Maximum Safe Load	150% Full Scale
Display Specifications	5-digit 15 mm Super High Brightness 30 mm red LED display Or 5-digit 40 mm LCD display with back lighting
Hanging Fixture	360-degree swirl safe hook & shackle
Operating Temperature	-25°C ~ +55°C
Environment Temperature	-10°C ~ +40°C
Operating Humidity	30% ~ 90% RH
Auto Power Off	30 minutes after the scale inactive or at extreme low power supply
Internal circuit with charging protection	To enhance the energy of battery and prolong its performing life
Scale casing	Die-casting aluminum housing, corrosion safe, anti-static and light weight
Keypad	Anti-corrosion, to prolong their working life.

■ Keypad operation

The keypad includes those keys such as ON/OFF, HOLD, SWITCH, ZERO. (Note: the above keys can be used in sub-menu to set up kg-lb conversion, Hold, Beeper On/Off, Zeroing and backlighting, etc.)

Model	Max. Capacity (kg)	Measured Division	Division Hi resolution
JC-600	600kg	0.2kg	0.1kg
JC-1000	1000kg	0.5kg	0.2 kg
JC-2000	2000kg	1kg	0.5 kg
JC-3000	3000kg	1kg	0.5 kg
JC-5000	5000kg	2kg	1 kg
JC-10t	10000kg	5kg	2 kg
JC-15t	15000kg	10kg	5 kg
JC-20t	20000kg	10kg	5 kg
JC-30t	30000kg	20kg	10 kg

- **[HOLD]** :

Press this key to keep the current weight and there is a LED indication lamp on the bottom of the display window. Press this key again when the displaying weight flickers to cancel the HOLD function.

- **[SWITCH]** :

Press this key to change between Measured Division and Hi resolution Division.

- **[ZERO]** :

Press this key to set the current weight to zero.

■ **General Scale Operations**

• **Turn On the Scale**

Press the power switch located under the displaying window of scale. The scale's maximum weighing capacity is first shown, and then the scale goes through a self-check sequence. 5 seconds later, the scale will stabilize and be ready for operation. (Note: it is recommended to allow scale 3~5 minutes of warm-up time before starting weighing operation).

• **Zeroing**

In general, the scale shows "0.0kg" or "0.00kg" after it is turned on. In case the display is showing numerical value other than "0", press [ZERO] on the keypad or the remote to set the display to "0".

• **Weight Measurement**

a) Once the load is suspended completely, the display shows the weight value of the load. When the "Stable" indicator is lit, weight value can be recorded.

b) In case there is tare such as cable, load the tare and press [ZERO] to zero the display to "0" kg. The weight value after this will be the net weight. This will not change until the tare change or the scale being turned off.

• **Turn Off the Scale**

After weighing operation, press the power switch to shut off the power completely to prevent the leakage of the battery.

■ **Battery Charging**

The scale adopts maintenance-free rechargeable battery and smart charger.

a. Then LOB indicator will be on if there is low power. The battery needs to be charged now. The scale, however, can continue to operate for about 5 hours without charging.

b. After the LOB indicator is ON for several hours without charging or there is no more power in the battery, the scale will be powered off automatically.

c. After battery charging, if there is no display, it indicates that either there is difficulty in battery charging or a damaged battery. Please contact supplier for repair or replacement.

To prolong the battery life, we suggest you charge the battery after using 48 hours or no less than once per week. To avoid any damage to the battery, please charge it correctly. Additionally, we suggest you switch off the scale to short the charging time. The charging lamp on the adaptor will turn to be red during charging. When the charging lamp on the adaptor becomes green, it means the battery is fully charged.

■ **Precautions**

- Please charge the scale with standard charger.
- The load placed on the scale hook must not exceed the maximum weighing capacity of the scale.
- Perform routine inspection and maintenance to ensure operation safety for these basic items:

- a) Check for loose bolts.
- b) Check hook and shackle for deformation, wearing and tearing.
- c) Check other scale component for signs of metal fatigue.
- d) Check for missing hook latch.
- e) Avoid hitting, bumping the display window.
- f) Do not use the scale in the rain or heavily polluted environment.
- g) If the scale is not going to be used for some time, please clean it, remove the battery and store it in dry conditions.

For problem “a” through “d”, please stop using the scale and send it back to your supplier for repair or replacement of problem parts.

■ **Calibration Method**

Please do not attempt to calibrate the scale without standard weight

Step	Operation	Display	Remarks
1	Press & Hold [ZERO] Key to power on	00000	Input the password “*****”
2	Press [ZERO] Key	SPEn	Enter into setting state, and make sure the scale is with non-load.
3	Press [HOLD] Key	Set 00000	It will display “00000” after 5 seconds.
4	Press [HOLD] Key to add Press [SWITCH] Key to move the digit left	3000	Load the scale. The closer to full capacity the better. For example, 3000kg
5	Press [ZERO]	HOLD	The scale will record the new calibration data.

■ Functions Setup in Sub-Menu

Function	Operation	Display	Remarks
Sets buzzer	Press [SWITCH] during self-check sequence from "99999" to "00000"	bEE 1	0: Disable 1: Enable Press [HOLD] or [SWITCH] to change.
HOLD function	Press [ZERO]	Hod 1	0: Disable 1: Enable Press [HOLD] or [SWITCH] to change.
Zero Function	Press [ZERO]	Stb 0	0: zeroing allowed when unstable 1: zeroing not allowed when unstable Press [HOLD] or [SWITCH] to change.
Backlighting setup	Press [ZERO]	Aut 1	0: Manual 1: to Auto press [HOLD] or [Switch] to change.
Sets units	Press [ZERO]	CHt 1	0: lb 1: kg
Save results	Press [ZERO]	YES 0	0: don't save 1: save Press [HOLD] or [SWITCH] to change.
-----	Press [ZERO]		Automatic re-start

■ Schematics

Dimensions of JC (15T, 20T, 30T)

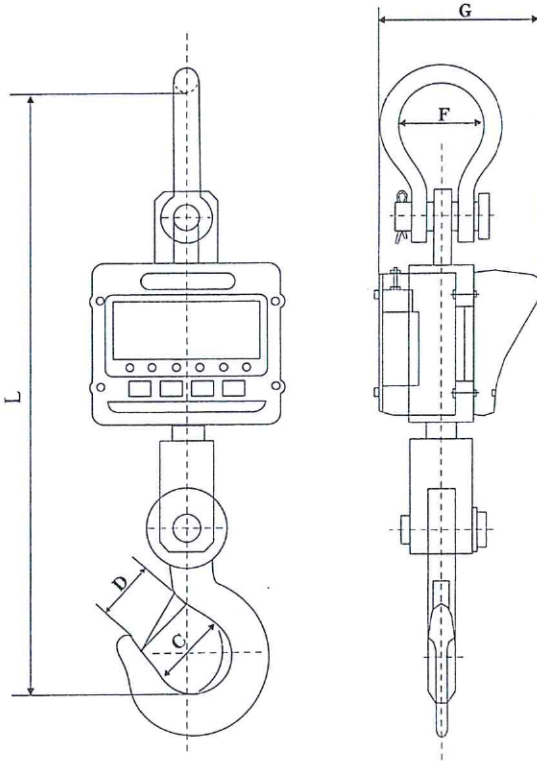

Model	L	F	C	G	D
JC-15t	897	135	85	270	60
JC-20t	984	150	90	270	73
JC-30t	1072	150	120	310	102

Dimensions of JC (600KG-15T)

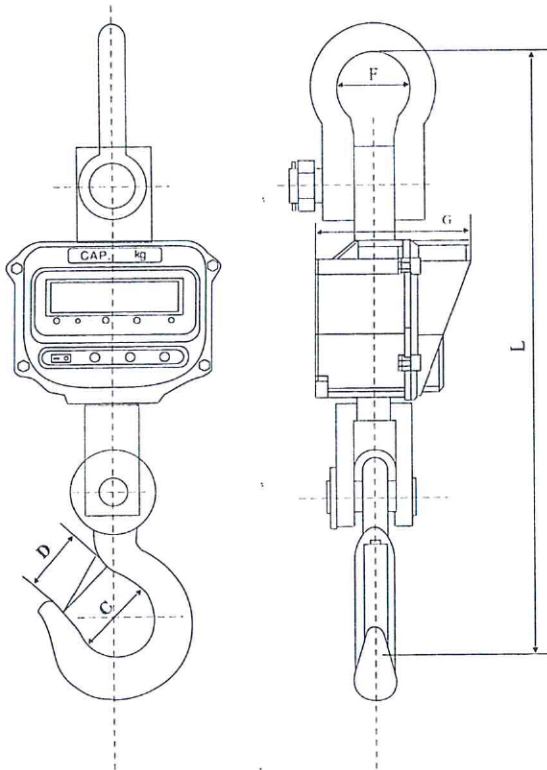

Model	L	F	C	G	D
JC-600	590	76	47	167	40
JC-1000	590	76	47	167	40
JC-2000	590	76	47	167	50
JC-3000	590	76	50	167	50
JC-5000	683	80	60	176	52
JC-10t	787	90	70	191	52
JC-15t	917	135	85	196	60

■ **Key pad functions of remote control** —————○

Key pad functions of remote control (This is for the scales with remote control)

【Zero】 : To zero the displaying weight.

【Hold】 : Keep the current displaying weight and the indicating lamp will be lit.

【+/BL】 : Turn on the backlighting. . (Only applies when the scale has a LCD display.)

【 Sw】 : Change the division value between measured division and hi-resolution division.

Note: This remote control is optional. Please state whether you need the remote on your purchasing order.

Please extend the antenna before using the remote control.

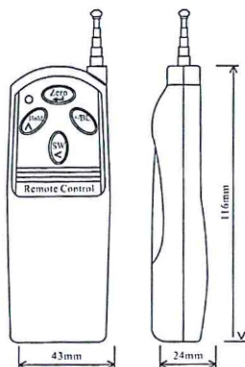

■ **Error Information** —————○

Err0: The calibration data should not less than 4 digits. Or the data will be invalid.

Err1: The calibration data should not exceed the data 65536

Err2: There is incorrect password to modify the calibration data.

Err3: The weight value at the calibration point is too small. It should be no less than 3 valid digits.

Err4: Incorrect calibration password. Please input the correct password.

Err5: The internal code at the calibration point is too small. The valid internal code is from 3000 to 65536.

Fault analysis by checking the internal code

Press [Zero] to power on the scale, it will first show "Ad". Then unpress the key, it will show the internal code. If there is no load on the scale, the internal code should be between 6000 and 8000. If the internal code is not in the range from 6000 to 8000, please send the scale back to your supplier for repair.

⚠ The products are subject to change without notice